

## 5 Tonne Electro-hydraulic Lift

- 5 Tonne lifting capacity
- Safety device in case of cable breakage
- Overload safety-valve
- Descent control valve
- Pipe burst safety valve
- 24V, low tension dead man controls
- Manufactured by OMA

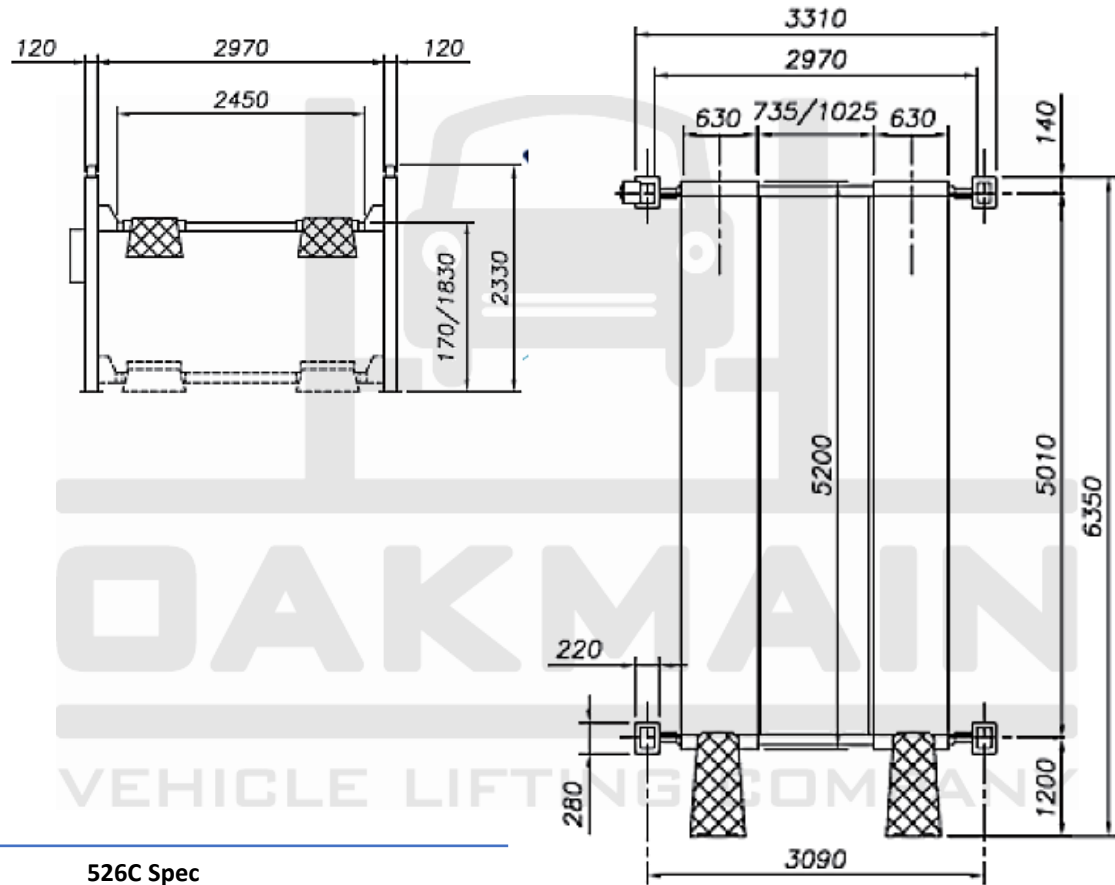



### 526C Spec

Lifting Capacity	5000kg
Weight	1440kg
Lifting Height	1830mm
Platform Length	5200mm
Motor	3kW – 3Ph 230-400V-50HZ
Lifting/Lowering Time	50/45s