



24BM Two Post 4 Tonne Electro-Hydraulic Vehicle Lift

Main Features

- Base plate design for low ceiling application
- Manual safety lock release system
- Aluminium motor
- Double height screw pads
- 60mm & 90mm lift pad extensions for 4x4 and vans
- Arm locking mechanisms (compliant with EN1493)

| | <i>24BM Spec</i> |
|--------------------|--------------------------|
| Lifting Capacity | 4000kg |
| Min Lifting Height | 100mm |
| Max Lifting Height | 1900mm |
| Motor | 220V/380V 50/60Hz |
| Power | 2.2kW |
| Inside column | 2830mm |
| Post height | 2904mm |
| Lifting Time | 55s |

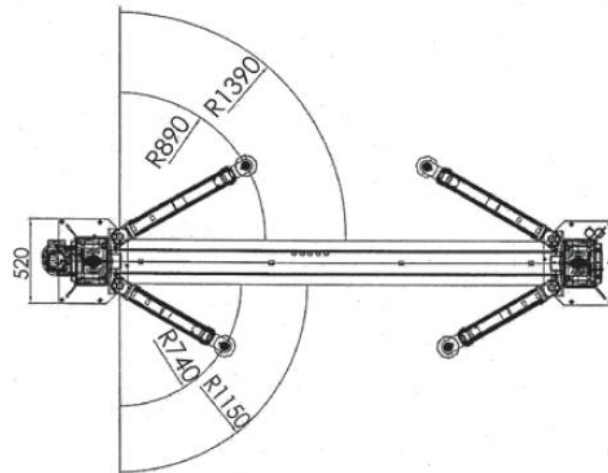
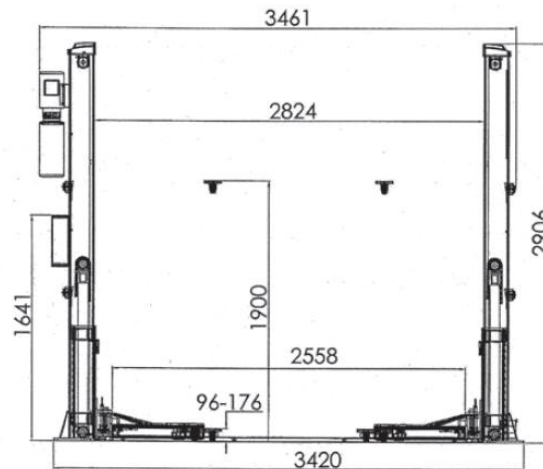

Arm locking mechanisms (compliant with EN1493)



Double height screw pads



Includes 60mm & 90mm lifting pad extensions