

526JCL5 Four Post 5 Tonne Electro-hydraulic Lift

Main Features

- Safety device in case of rope breaking
- Overload safety-device
- Descent control valve
- Safety-valve in case of sudden loss of pressure
- "Dead man" controls 24V
- Electrical controlled fall safety
- Automatic descent control
- Soundproof safety devices
- Fitted with Play Detectors
- Fitted with Turn Plates for Wheel Alignment

	<i>526JCL5 Spec</i>
Lifting Capacity	5000kg
Weight	1500/1610kg
Lifting Height	1830mm
Platform Length	5700mm
Overall length of lift	6840mm
Post height	2330mm
Motor	3kW – 3Ph 230-400V-50HZ
Lifting & Lowering Time	30s

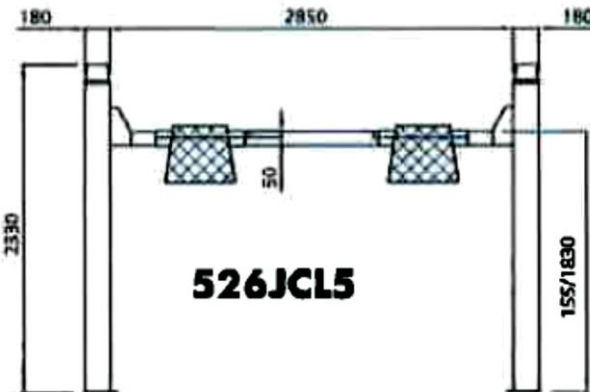
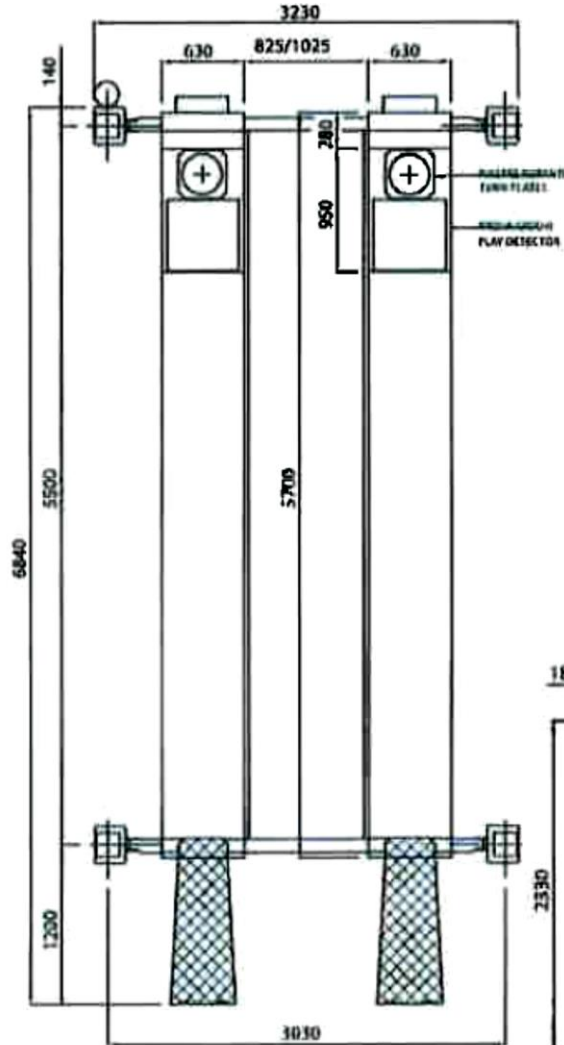

Manufactured by OMA



526JCL5